

Installation Manual

P/N MMI-20012740, Rev. BA

February 2009

Micro Motion[®] **Model 2200S Transmitters**

Installation Manual



Contents

Chapter 1	Before You Begin	1
1.1	Overview	1
1.2	Safety	1
1.3	Interpreting your model number	1
1.4	Overview of flowmeter components and installation architectures	2
	1.4.1 Transmitter	2
	1.4.2 mA output and rescaling	2
1.5	Transmitter installation overview	4
1.6	Flowmeter documentation	5
1.7	Customer service	5
Chapter 2	Installation Considerations	7
2.1	Overview	7
2.2	Transmitter power requirements	7
2.3	Barrier requirements	8
	2.3.1 Barrier power requirements	8
	2.3.2 Third-party barriers verified by Micro Motion	8
2.4	Locating the components	9
2.5	Installation tips	9
Chapter 3	Transmitter and Barrier Installation	11
3.1	Overview	11
3.2	Installing the extender	11
3.3	Rotating the transmitter on the sensor (optional)	13
3.4	Rotating the user interface module on the transmitter (optional)	14
3.5	Grounding the transmitter	15
3.6	Installing the Micro Motion adapter-barrier	15
3.7	Installing a third-party barrier	15
Chapter 4	Wiring	17
4.1	Overview	17
4.2	Wiring for installations without a barrier or adapter-barrier	17
4.3	Wiring for installations with a third-party barrier or Micro Motion adapter-barrier	18

Appendix A	Dimensions and Specifications	23
A.1	Dimensions	23
A.2	Physical specifications	24
A.3	Power supply	24
A.4	Electrical connections	24
A.5	User interface	24
A.6	Input/output signals	25
A.7	Digital communications	25
A.8	Host interface	25
A.9	Environmental limits	25
A.10	Environmental effects	25
A.11	Hazardous area classifications	26
Appendix B	Micro Motion Adapter-Barrier	27
B.1	Overview	27
B.2	About the Micro Motion adapter-barrier	27
B.3	Dimensions and specifications	28
B.4	Mounting and removing the Micro Motion adapter-barrier	30
B.5	Unlocking and locking the Micro Motion adapter-barrier	30
B.6	Configuring active or passive loop power	30
B.7	Calibrating the mA output of the Micro Motion adapter-barrier	31
B.8	Resetting the Micro Motion adapter-barrier to factory calibration values	32
Appendix C	Return Policy	33
C.1	General guidelines	33
C.2	New and unused equipment	33
C.3	Used equipment	33
Index		35

Chapter 1

Before You Begin

1.1 Overview

This chapter provides an orientation to the use of this manual. This manual describes the procedures required to install the Model 2200S transmitter.

If you are installing your transmitter in a hazardous area, be sure the transmitter is approved for that area.

1.2 Safety

Safety messages are provided throughout this manual to protect personnel and equipment. Read each safety message carefully before proceeding to the next step.



If you are installing the transmitter in a hazardous area, refer to Micro Motion approval instructions, shipped with the product or available from the Micro Motion web site. Improper installation in a hazardous area can cause an explosion.



Follow all instructions. Improper installation could cause measurement error or flowmeter failure.

1.3 Interpreting your model number

Model 2200S transmitter options are encoded in the model number located on the transmitter tag. The model number is a string of the following form:

2200S*(H or K)*****

In this string:

- **H** = Micro Motion adapter-barrier not supplied with the transmitter
- **K** = Micro Motion adapter-barrier supplied with the transmitter

Note: See the product data sheet for information on the remaining characters in the model number.

Before You Begin

1.4 Overview of flowmeter components and installation architectures

A Model 2200S installation includes the following components:

- Transmitter
- Sensor
- Micro Motion adapter-barrier or third-party barrier (optional)

If the flowmeter is in a safe area, no barrier is required between the flowmeter and external devices. If the flowmeter is in a hazardous area, a barrier may be required between the flowmeter and external devices. See Sections 1.4.2 and 2.3 for more information about barrier options and requirements.

1.4.1 Transmitter

The Model 2200S transmitter is mounted on a Micro Motion sensor, in one of two mounting options: integral-mount or extended-mount. See Figures 1-1 and 1-2.

Figure 1-1 Model 2200S transmitter – Integral-mount

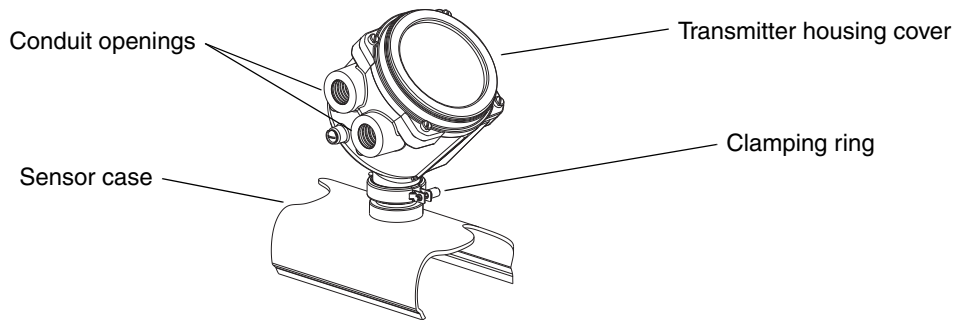
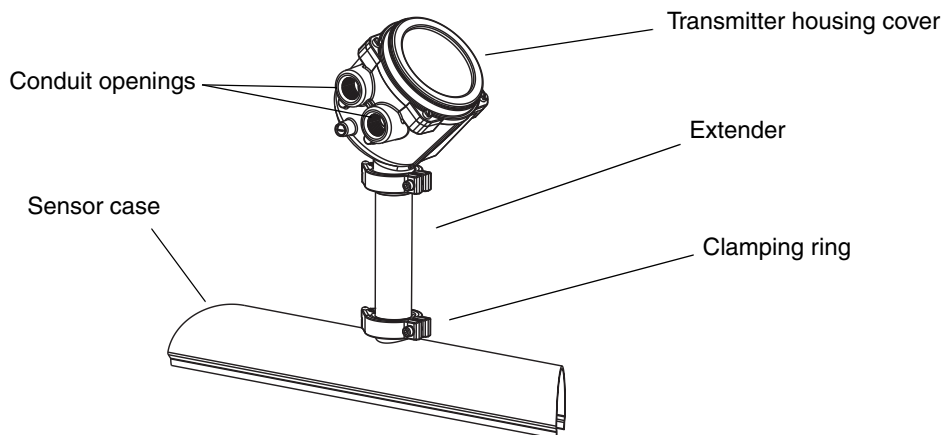

Figure 1-2 Model 2200S transmitter – Extended-mount



1.4.2 mA output and rescaling

In installations with no barrier or a third-party barrier, the mA signal received by the external device will be scaled from 12 mA to 20 mA. Any rescaling must occur in the external device. In installations with the Micro Motion adapter-barrier, the external device will receive a 4–20 mA signal.

Before You Begin

These installation architectures are illustrated in the following figures:

- Type 1 installations (Figure 1-3) – safe area installation with 12–20 mA output scaling
- Type 2 installations (Figure 1-4) – hazardous area installation with a third-party barrier and 12–20 mA output scaling
- Type 3 installations (Figure 1-5) – hazardous area installation with the Micro Motion adapter-barrier and 4–20 mA output scaling

Figure 1-3 Type 1 installations – Safe area installation

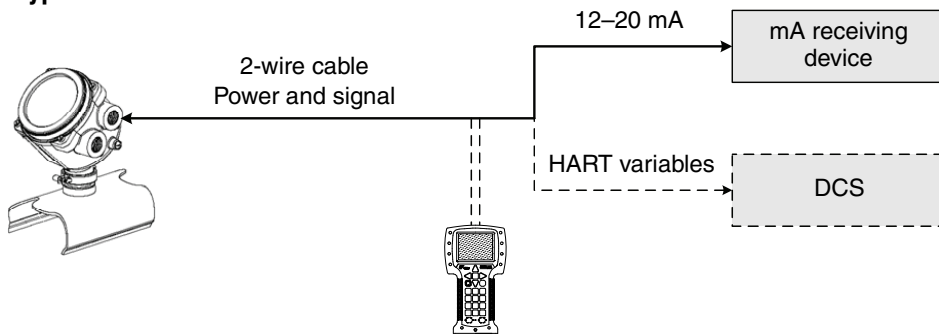

Figure 1-4 Type 2 installations – Hazardous area installation with third-party barrier

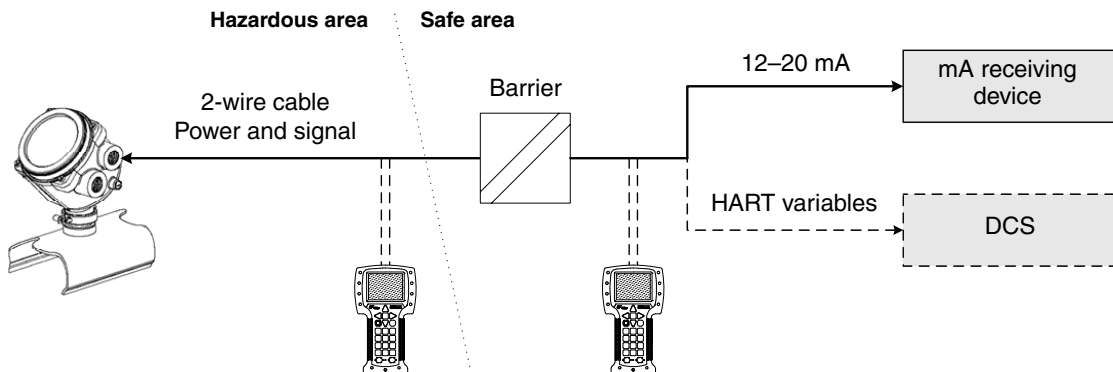
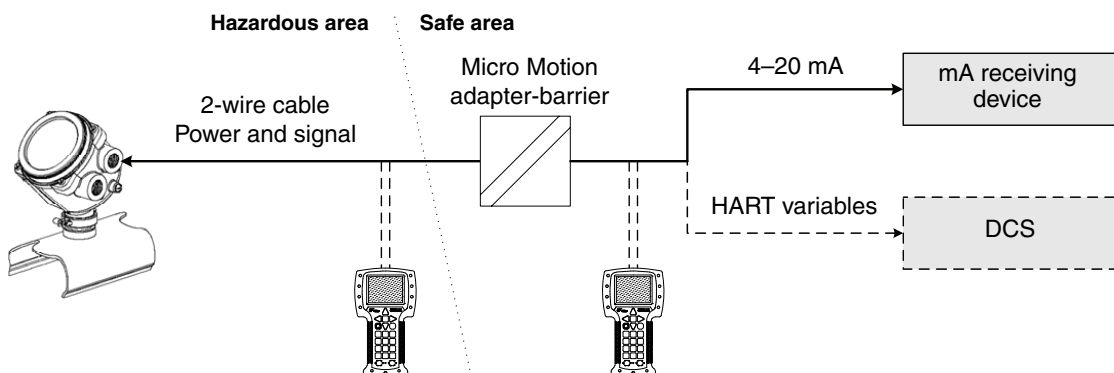

Figure 1-5 Type 3 installations – Hazardous area installation with Micro Motion adapter-barrier



1.5 Transmitter installation overview

The flowchart in Figure 1-6 provides an overview of installation steps. Additional information and instructions are provided in following chapters.

Figure 1-6 Installation overview

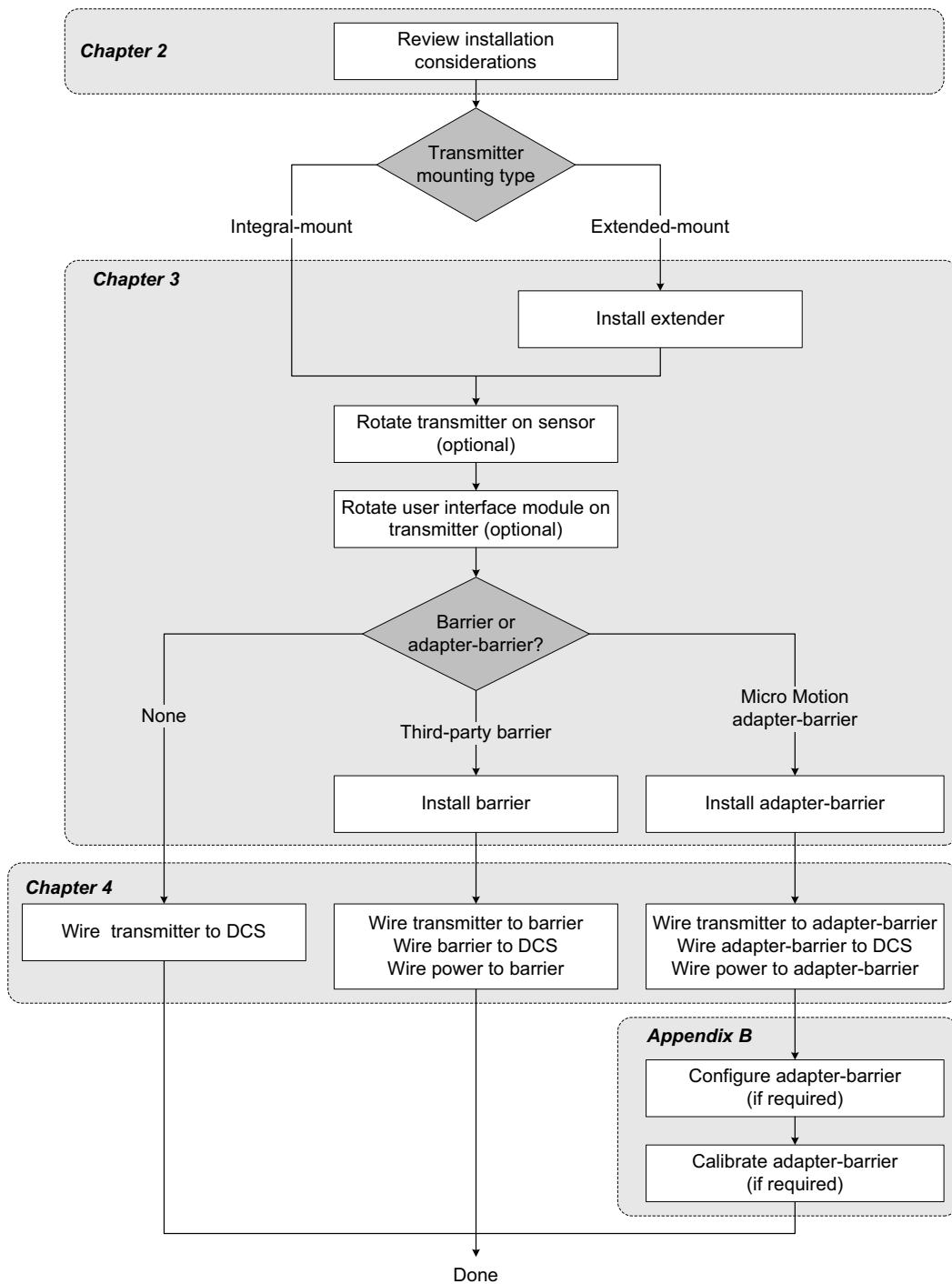

1.6 Flowmeter documentation

Table 1-1 lists documentation sources for other required information.

Table 1-1 Flowmeter documentation resources

Topic	Document
Sensor installation	Sensor documentation shipped with sensor
Hazardous area installation	See the approval documentation shipped with the transmitter, or download the appropriate documentation from the Micro Motion web site (www.micromotion.com)
Transmitter configuration Transmitter startup and use Transmitter troubleshooting	<i>Micro Motion® Model 2200S Transmitters: Configuration and Use Manual</i>

1.7 Customer service

For technical assistance, phone the Micro Motion Customer Service department:

- In the U.S.A., phone 800-522-MASS (800-522-6277) (toll free)
- In Canada and Latin America, phone +1 303-527-5200 (U.S.A.)
- In Asia:
 - In Japan, phone 3 5769-6803
 - In other locations, phone +65 6777-8211 (Singapore)
- In Europe:
 - In the U.K., phone 0870 240 1978 (toll-free)
 - In other locations, phone +31 (0) 318 495 555 (The Netherlands)

Customers outside the U.S.A. can also email Micro Motion customer service at *International.MMISupport@EmersonProcess.com*.

Chapter 2

Installation Considerations

2.1 Overview

This chapter includes the following topics:

- Transmitter power requirements – see Section 2.2
- Barrier requirements – see Section 2.3
- Component location – see Section 2.4
- Installation tips – see Section 2.5

2.2 Transmitter power requirements

The supply voltage required by the Model 2200S transmitter depends on the total resistance in the mA loop. This includes all sensor resistance and wire resistance. Use the chart in Figure 2-1 to determine required supply voltage based on loop resistance.

Figure 2-1 Minimum loop supply voltage vs. loop resistance – Transmitter

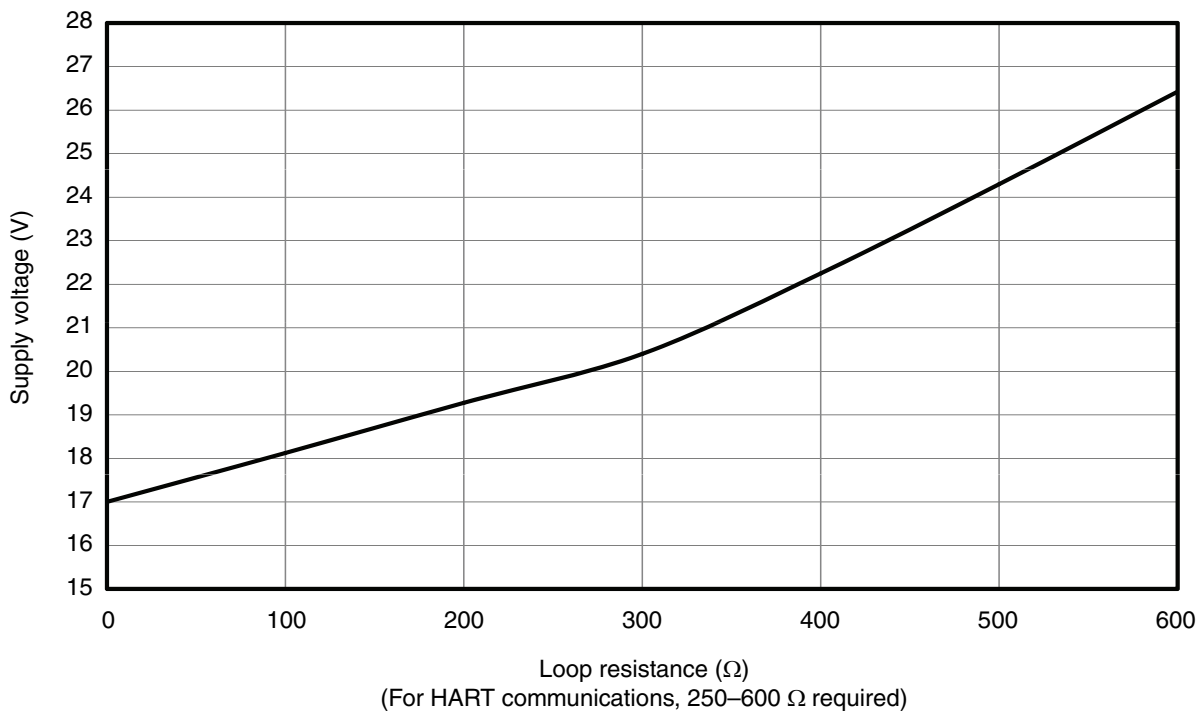

2.3 Barrier requirements

If a barrier is required, there are two options:

- Micro Motion adapter-barrier (shown in Figure 2-2). This component provides galvanically isolated, intrinsically safe power to the Model 2200S transmitter and rescales the 12–20 mA output of the Model 2200S transmitter to 4–20 mA.
- Third-party barrier

The barrier is connected to the transmitter via a 2-wire cable. This cable supplies power to the transmitter, and also carries the mA/HART signal from the transmitter to the barrier. The barrier is connected to external devices via a 2-wire cable that carries the mA/HART signal.

Figure 2-2 Micro Motion adapter-barrier

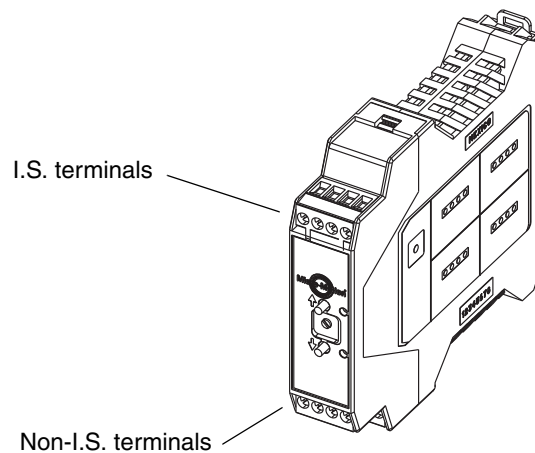

2.3.1 Barrier power requirements

Power must be supplied to the barrier or adapter-barrier.

- The Micro Motion adapter-barrier requires 18–42 VDC.
- For third-party barriers, see the vendor documentation.

The barrier or adapter-barrier may be active or passive:

- Active – the loop between the barrier and the host is powered by the barrier
- Passive – the loop between the barrier and the host is not powered by the barrier

A third-party barrier must be capable of delivering the following voltages at the transmitter terminals:

- 17 V (minimum) at 12 mA
- 12.25 V (minimum) at 20 mA

2.3.2 Third-party barriers verified by Micro Motion

Table 2-1 lists the third-party barriers that Micro Motion has verified with the Model 2200S transmitter. For other barriers, refer to the manufacturer's data sheet.

Table 2-1 Third-party barriers verified by Micro Motion

Vendor	Barrier
MTL	3046
	5042
	706S+
	787S+
Pepperl & Fuchs	KFD2-STC1-EX1 (300 Ω maximum on system side)
	KFD2-STC4-EX1
PR Electronics	5106

2.4 Locating the components

When choosing locations for components, refer to the following guidelines:

- See the sensor installation manual for information on locating the sensor with integral-mount or extended-mount electronics.
- Ensure that each component has all required approvals for its location, and that all cable meets the applicable hazardous area requirements.
- Do not install a component in a location where its temperature, humidity, or vibration limits will be exceeded.
- Maximum distance between components depends on the wire size, the wire type, and the power supply. Ensure that sufficient power is supplied to the transmitter terminals.

2.5 Installation tips

To optimize the use and reliability of the flowmeter:

- Install the sensor and transmitter in a location and orientation that will allow easy access to the terminals and to the display.
- Minimize the amount of moisture or condensation inside the transmitter housing. Moisture inside the transmitter housing can damage the transmitter and cause measurement error or flowmeter failure. To do this:
 - Ensure that the conduit openings do not point upward.
 - Ensure the integrity of all gaskets and O-rings.
 - Install drip legs on conduit or cable.
 - Seal unused conduit openings.
 - Ensure that all covers are fully tightened.

Chapter 3

Transmitter and Barrier Installation

3.1 Overview

This chapter includes the following topics and procedures:

- Installing the extender (if required) – see Section 3.2
- Rotating the transmitter on the sensor (optional) – see Section 3.3
- Rotating the user interface module on the transmitter (optional) – see Section 3.4
- Grounding the transmitter – see Section 3.5
- Installing the Micro Motion adapter-barrier (if required) – see Section 3.6
- Installing the third-party barrier (if required) – see Section 3.7

3.2 Installing the extender

Note: This step is required only for extended-mount devices.

The transmitter is pre-installed on the extender. To install the extender on the sensor:

1. Referring to Figure 3-1:
 - a. Remove the metal clamping ring from the base of the feedthrough, and set it aside to use later.
 - b. Remove and discard the plastic cap that was used to protect the feedthrough pins.
2. Referring to Figure 3-2:
 - a. Remove and discard the plastic plug inside the base of the extender.
 - b. Place the extender onto the feedthrough and rotate it until the feedthrough notches line up.
 - c. Carefully push the extender onto the feedthrough until the pins are fully engaged.
CAUTION! Do not twist, bend, or damage the feedthrough pins.
3. Replace the clamping ring on the feedthrough. Tighten the screw to 13–18 in-lbs (1.5–2 N-m).
CAUTION! Ensure that the connection between the extender and the sensor is moisture-proof. Inspect and grease all gaskets and O-rings. Moisture in the electronics can cause measurement error or flowmeter failure.

Figure 3-1 Feedthrough, plastic cap, and clamping ring

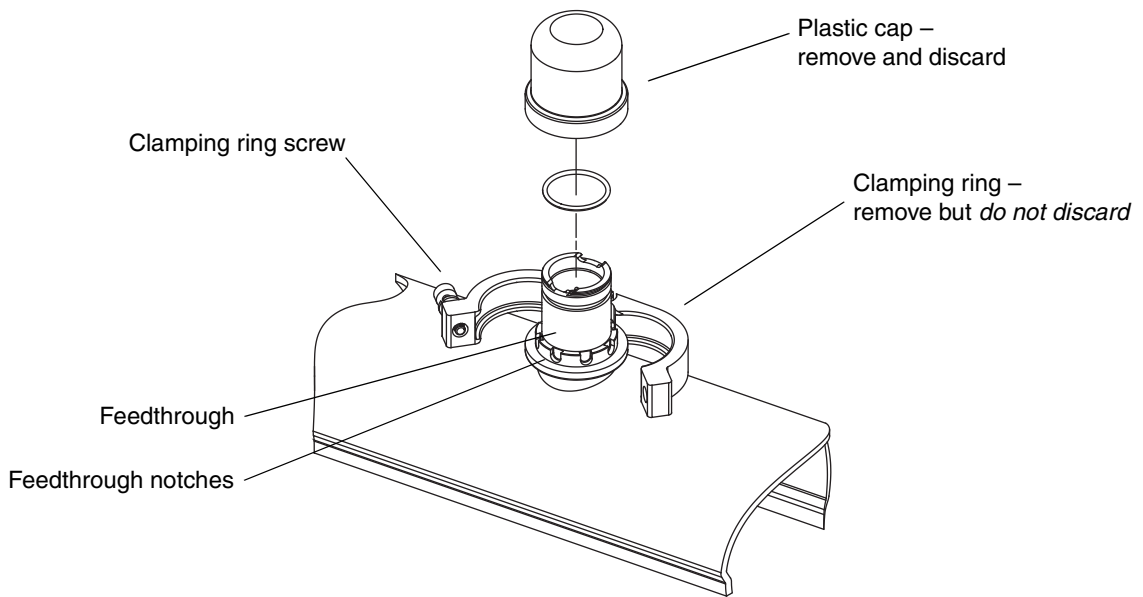
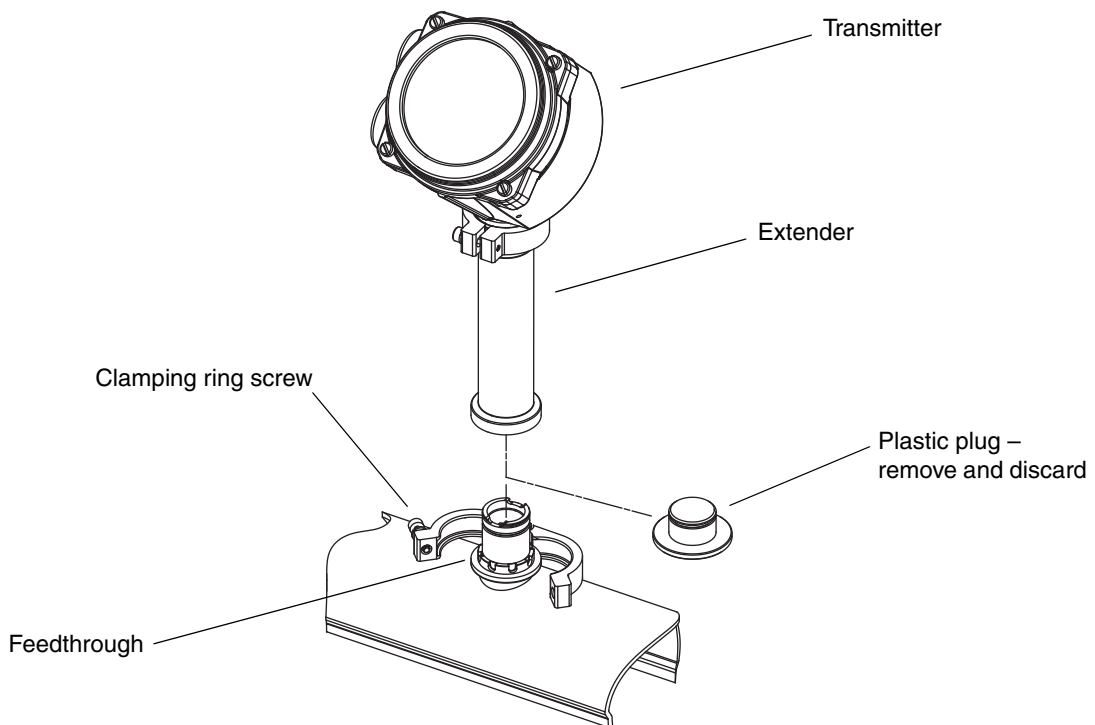

Figure 3-2 Mounting the extender onto the sensor



3.3 Rotating the transmitter on the sensor (optional)

For easier access to the user interface or the wiring terminals, the transmitter can be rotated on the sensor in 45° increments, for eight different orientations.

To rotate the transmitter on the sensor:

1. Referring to Figure 3-3, remove the metal clamping ring from the base of the feedthrough.
2. Gently lift the transmitter on the feedthrough until it disengages from the notches on the feedthrough. You will not be able to remove the transmitter completely.
3. Rotate the transmitter to the desired position. **CAUTION! Do not rotate the housing more than 360°. Excessive rotation can damage the wiring and cause measurement error or flowmeter failure.**
4. Lower the transmitter, sliding it onto the notches on the feedthrough.
5. Replace the clamping ring on the feedthrough. Tighten the screw to 13–18 in-lbs (1.5–2 N-m). **CAUTION! Ensure that the connection between the transmitter and the sensor is moisture-proof. Inspect and grease all gaskets and O-rings. Moisture in the electronics can cause measurement error or flowmeter failure.**

Figure 3-3 Rotating the transmitter on the sensor

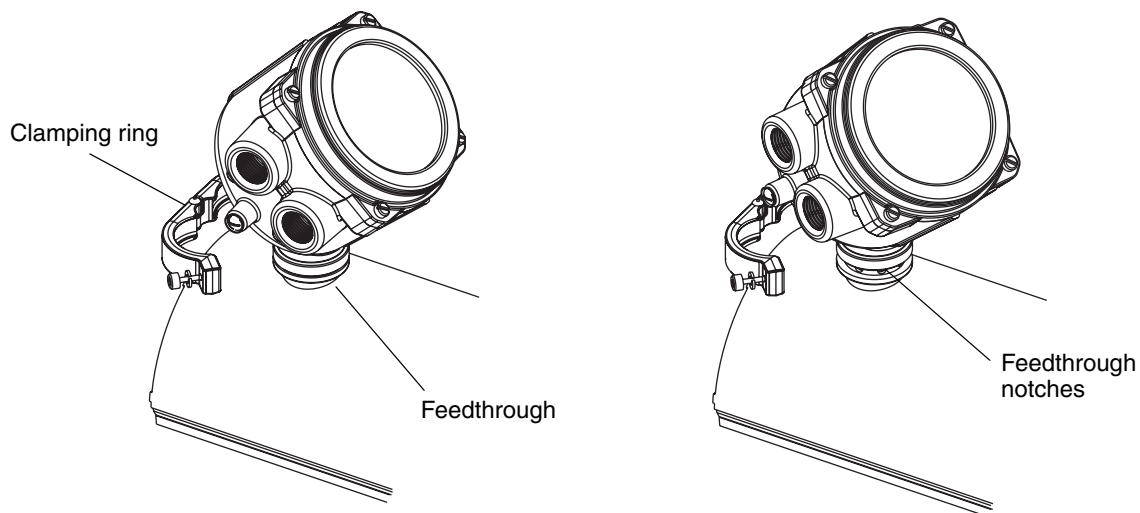

3.4 Rotating the user interface module on the transmitter (optional)

For easier access, the user interface module can be rotated on the transmitter up to 360° in 90° increments.

To rotate the user interface module on the transmitter:

1. Remove power from the transmitter.
2. Referring to Figure 3-4, remove the transmitter housing cover and user interface module:
 - a. Loosen the four transmitter housing cover screws.
 - b. Remove the transmitter housing cover.
 - c. Loosen the two user interface screws.
 - d. Gently lift the user interface module, disengaging it from the user interface connector on the transmitter.
3. On the back of the user interface module, four user interface connectors are provided. Rotate the user interface module to the desired position and plug it into the user interface connector on the transmitter.
4. Tighten the user interface screws.
5. Replace the transmitter housing cover and tighten the transmitter housing cover screws.
6. Restore power to the transmitter.

Figure 3-4 Rotating the user interface module on the transmitter

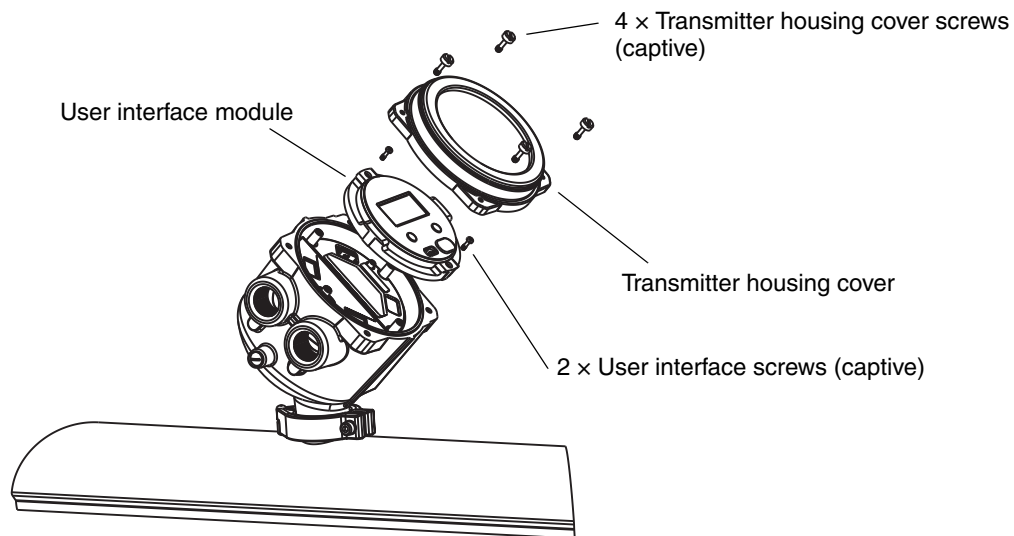

3.5 Grounding the transmitter

The Model 2200S transmitter is grounded via the sensor. See the sensor installation manual for grounding requirements and procedures. No additional grounding is required.



Ensure that the flowmeter is appropriately grounded. Improper grounding can cause measurement error.

3.6 Installing the Micro Motion adapter-barrier

Note: This step is required only for installations that include the Micro Motion adapter-barrier.

Install the Micro Motion adapter-barrier according to the instructions in Appendix B.

The adapter-barrier is set to “active” at the factory, i.e., the adapter-barrier powers the loop to the host. If you do not want the adapter-barrier to power the loop, reconfigure the adapter-barrier. Instructions are provided in Section B.6.

3.7 Installing a third-party barrier

Note: This step is required only for installations that include a third-party barrier.

If you are using a third-party barrier, install and configure the barrier according to the vendor instructions.

Chapter 4

Wiring

4.1 Overview

This chapter includes the following topics and procedures:

- Wiring for installations without a barrier or adapter-barrier – see Section 4.2
- Wiring for installations with a barrier or adapter-barrier – see Section 4.3



Ensure that wiring meets or exceeds all applicable code requirements. A device that has been improperly wired in a hazardous area can cause an explosion.

4.2 Wiring for installations without a barrier or adapter-barrier

In these installations, the Model 2200S transmitter is wired directly to the host.

To wire the transmitter to the host:

1. Refer to the wiring diagram in Figure 4-1.
2. Use standard twisted-pair shielded wire.
3. Ensure that all wire lengths are within the maximum wire length as determined by the loop resistance.
4. At the Model 2200S transmitter:
 - a. Remove the transmitter housing cover and user interface module as described in Section 3.4, Step 2.
 - b. Unscrew the Warning flap screw and raise the Warning flap.
 - c. Connect the wires to terminals 1 and 2. Terminals 1 and 2 are polarity-insensitive.
 - d. Lower the Warning flap and tighten the Warning flap screw.
 - e. Replace the user interface module and transmitter housing cover.
5. At the host, connect the wires to the mA terminals. See the vendor documentation for assistance in identifying the terminals.
6. Supply power to the loop and add resistance as required.

Figure 4-1 Wiring for installations without a barrier or adapter-barrier

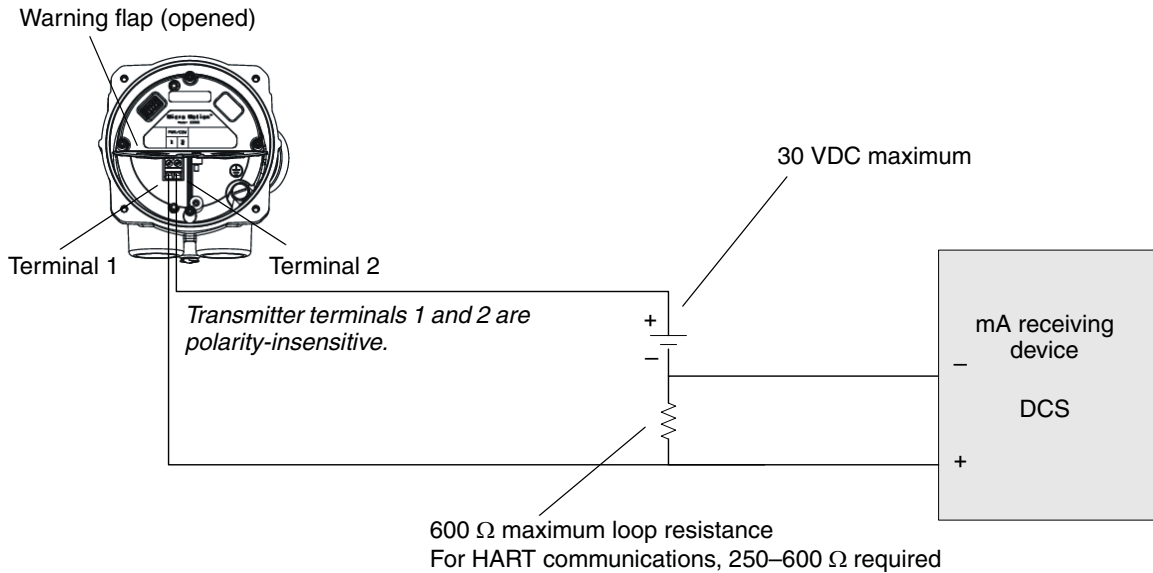

4.3 Wiring for installations with a third-party barrier or Micro Motion adapter-barrier

In these installations, the Model 2200S transmitter is wired to the barrier or Micro Motion adapter-barrier. The barrier is then wired to the host and to an external power supply. Power and resistance requirements depend on the barrier and the host. Refer to local installation requirements.

Note: Adapt the following instructions to your barrier (if you are using a third-party barrier) and your host. Figures 4-5 and 4-6 illustrate typical wiring scenarios for third-party barriers, but your case may be different. See the vendor documentation for assistance in identifying the terminals and for specific wiring, power, and resistance requirements.

To wire the transmitter to the host via a third-party barrier or Micro Motion adapter-barrier:

1. Use standard twisted-pair shielded wire.
2. Ensure that all wire lengths are within the maximum wire length as determined by the loop resistance.
3. See the appropriate wiring diagram for your barrier and power type:
 - For an active Micro Motion adapter-barrier (the adapter-barrier powers the loop), see Figure 4-2. “Active” is the factory setting.
 - For a passive Micro Motion adapter-barrier (the adapter-barrier does not power the loop), see Figure 4-3. Ensure that you have reconfigured the adapter-barrier to “passive.”
 - For an active third-party barrier, see Figure 4-5.
 - For a passive third-party barrier, see Figure 4-6.
4. At the Model 2200S transmitter:
 - a. Remove the transmitter housing cover and user interface module as described in Section 3.4, Step 2.
 - b. Unscrew the Warning flap screw and raise the Warning flap.
 - c. Connect the wires to terminals 1 and 2. Terminals 1 and 2 are polarity-insensitive.
 - d. Lower the Warning flap and tighten the Warning flap screw.
 - e. Replace the user interface module and transmitter housing cover.

5. At the barrier or adapter-barrier:
 - a. Wire the I.S. terminals on the component to terminals 1 and 2 on the Model 2200S transmitter. Terminals 1 and 2 are polarity-insensitive.
 - b. Wire the non-I.S. terminals on the component to the mA terminals on the mA receiving device and add resistance as required.
 - c. Wire power to the barrier. Terminals 11 and 12 on the Micro Motion adapter-barrier are polarity-insensitive. If you are using a third-party barrier, refer to the vendor documentation for polarity information.
6. If you have a passive barrier or adapter-barrier, connect the loop to an external power source and add resistance as required.

Figure 4-2 Wiring for installations with Micro Motion adapter-barrier, active

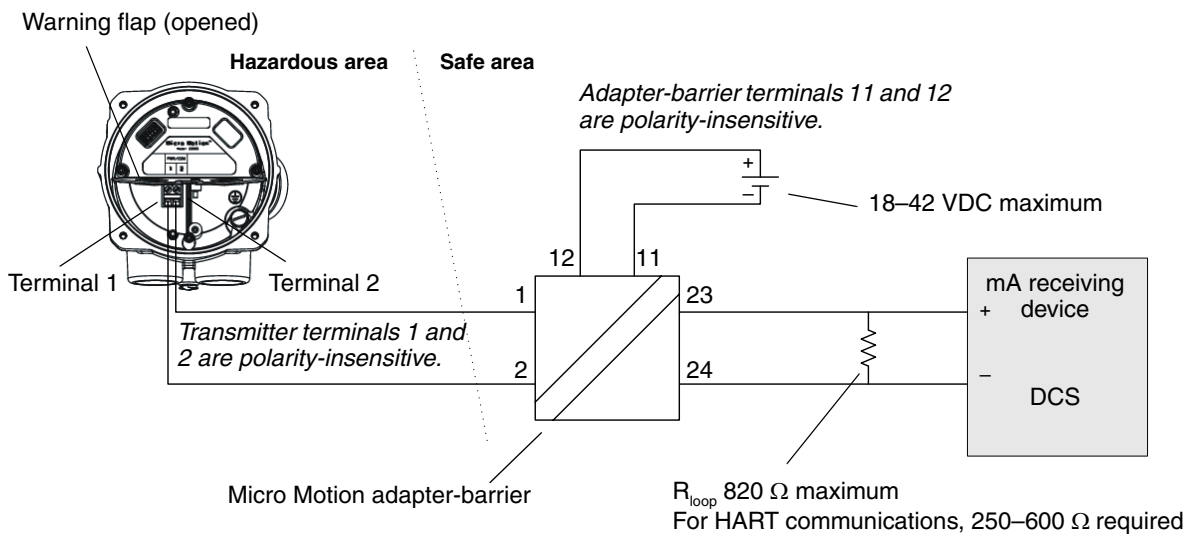

Figure 4-3 Wiring for installations with Micro Motion adapter-barrier, passive

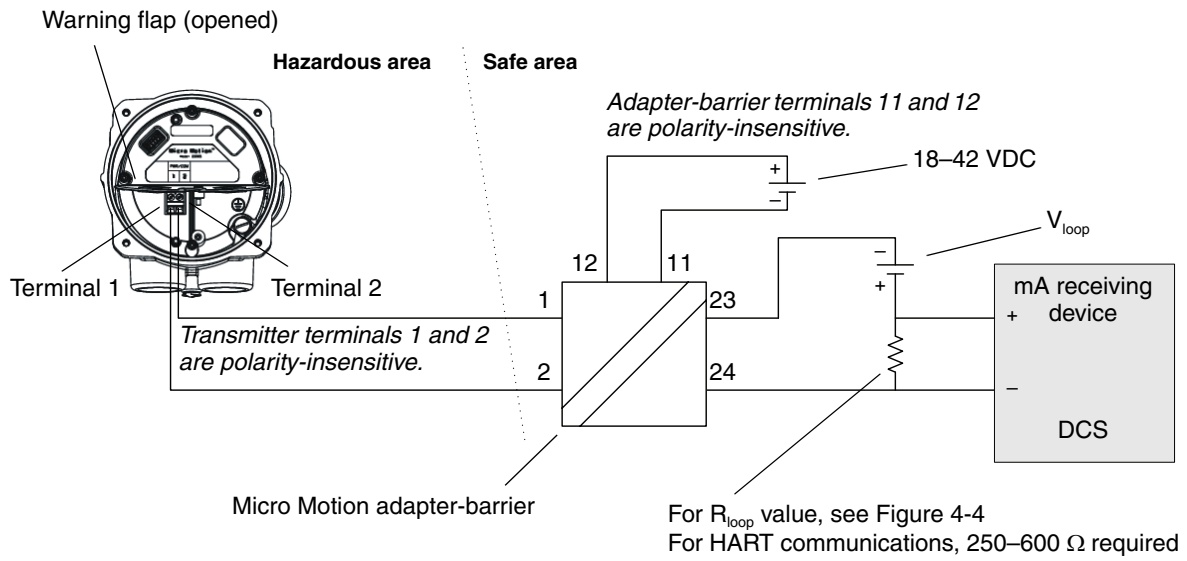

Figure 4-4 Minimum loop supply voltage vs. loop resistance – Micro Motion adapter-barrier, passive

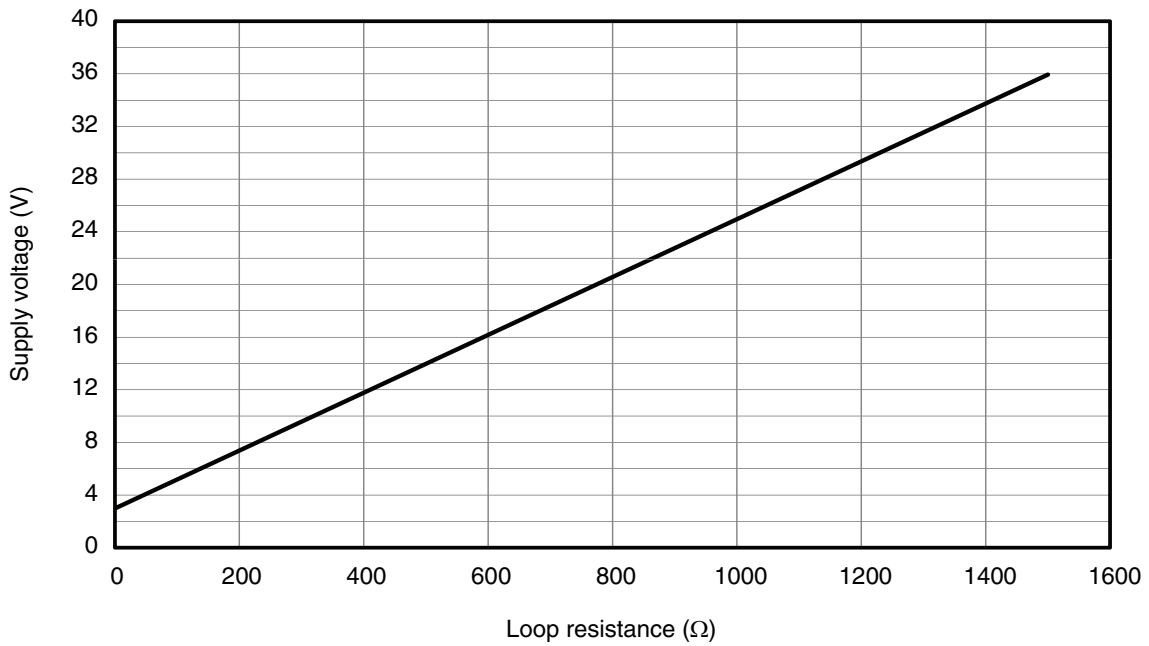

Figure 4-5 Typical wiring for installations with third-party barrier, active

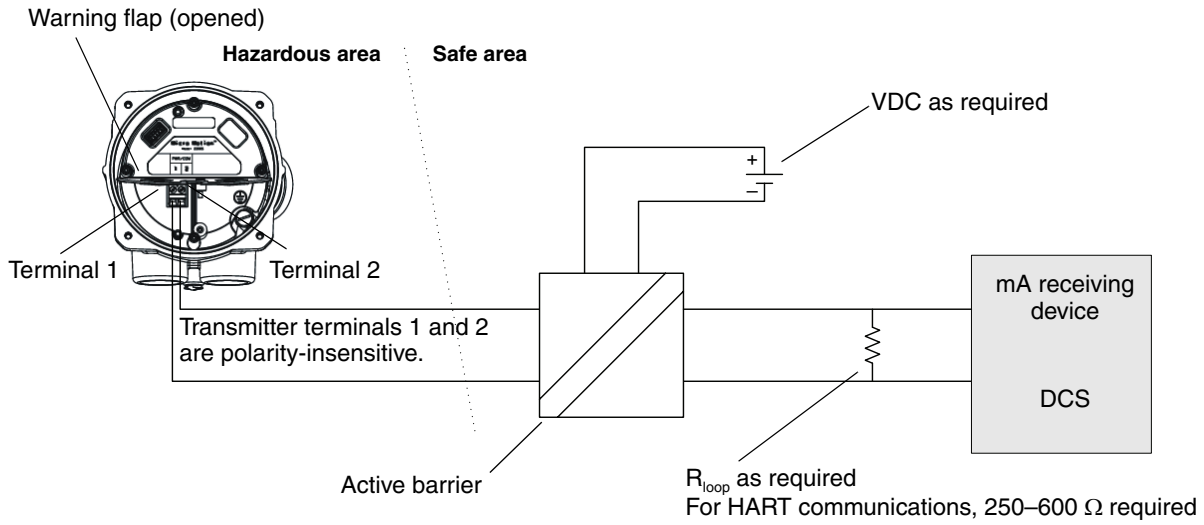
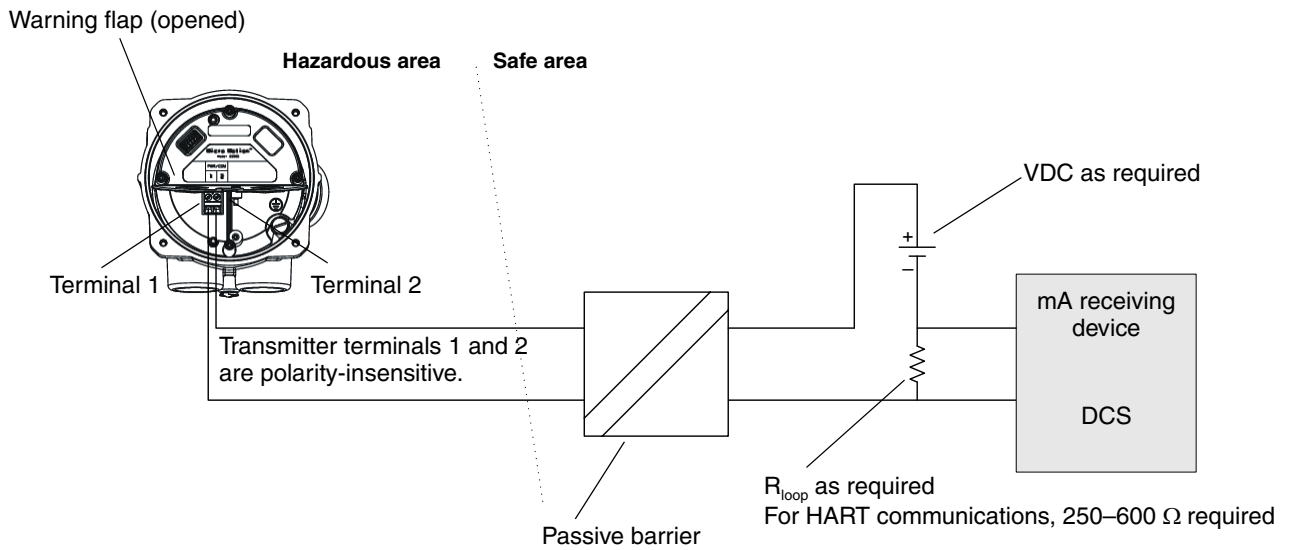

Figure 4-6 Typical wiring for installations with third-party barrier, passive



Appendix B

Micro Motion Adapter-Barrier

B.1 Overview

This appendix includes the following topics and procedures:

- Introduction to the Micro Motion adapter-barrier – see Section B.2
- Dimensions and specifications – see Section B.3
- Mounting and removing the Micro Motion adapter-barrier – see Section B.4
- Locking and unlocking the Micro Motion adapter-barrier – see Section B.5
- Configuring the Micro Motion adapter-barrier for active or passive loop power – see Section B.6
- Calibrating the Micro Motion adapter-barrier – see Section B.7
- Resetting the Micro Motion adapter-barrier to factory calibration values – see Section B.8

B.2 About the Micro Motion adapter-barrier

The Micro Motion adapter-barrier provides galvanically isolated, intrinsically safe power to the Model 2200S transmitter. On the field side, the adapter-barrier is wired to a Micro Motion sensor. On the system side, it is wired to a host. The adapter-barrier rescales the 12–20 mA output from the Model 2200S transmitter to 4–20 mA.

By default, the adapter-barrier is set to “active,” i.e., it powers the system-side loop. The adapter-barrier can be reconfigured to “passive,” i.e., it does not power the system-side loop.

The adapter-barrier’s mA output to the host can be calibrated, and the calibration can be reset to factory values.

Switches and buttons on the adapter-barrier are used to configure and calibrate the device. The front panel of the adapter-barrier is shown in Figure B-1.

In normal use, the adapter-barrier is locked. If it is locked, you must unlock it before you can configure it or calibrate it.

Micro Motion Adapter-Barrier

Figure B-1 User interface

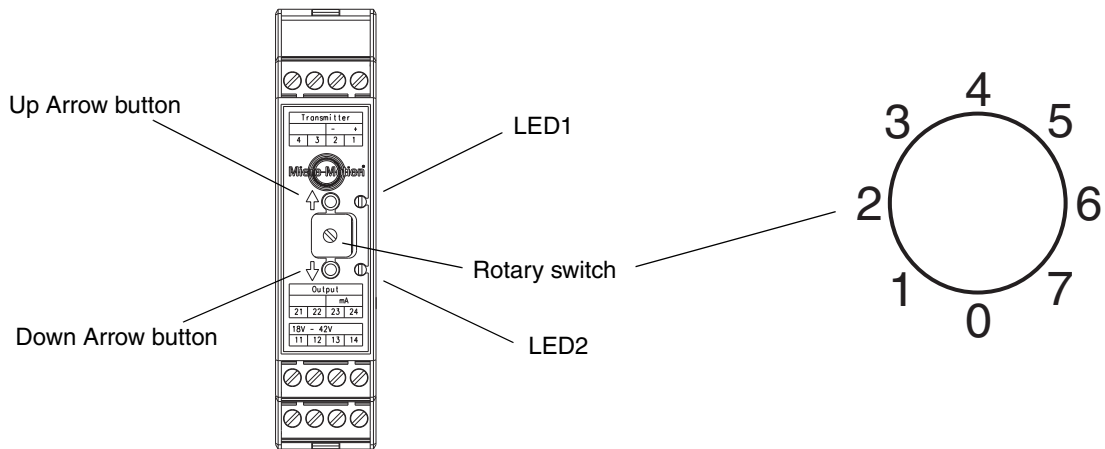

B.3 Dimensions and specifications

Figure B-2 Dimensions

Dimensions in inches
(mm)

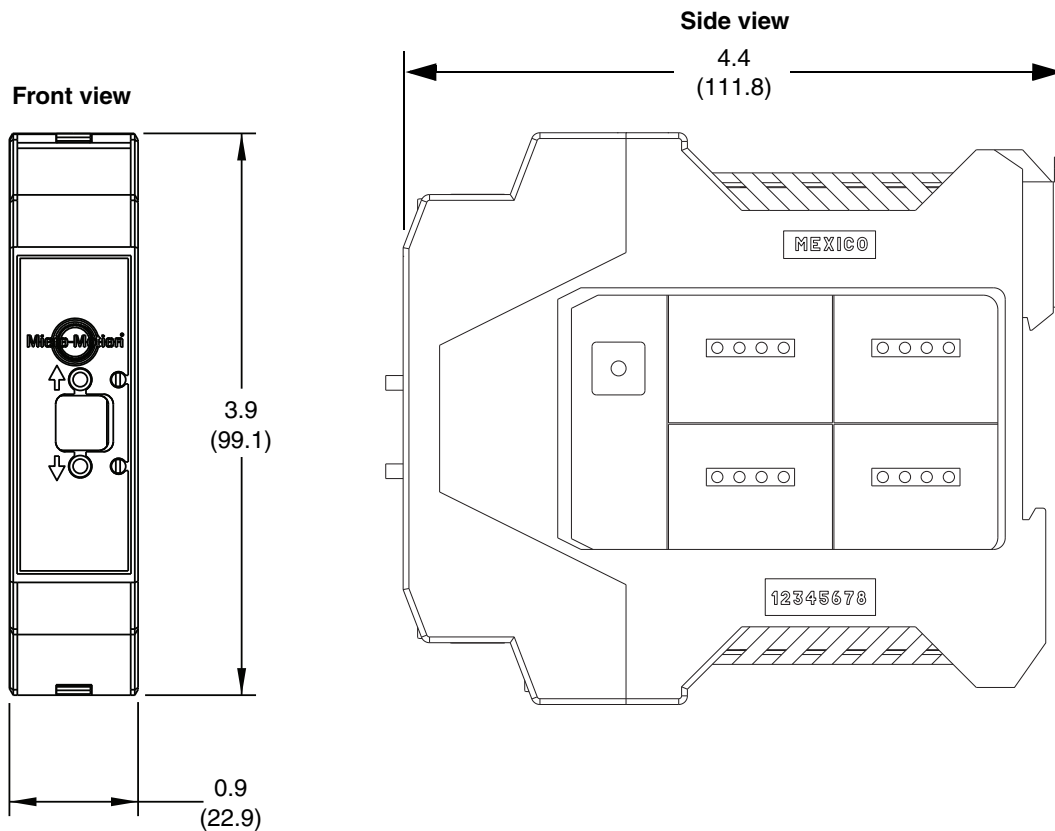

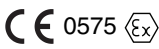

Table B-1 Specifications

12–20 mA to 4–20 mA barrier with HART pass-through

Physical	IP20 DIN rail mounting type: DIN 46277 Weight: 0.33 lb (0.15 kg) Can be stacked side by side
Temperature limits	Ambient temperature: –40 to +140 °F (–40 to +60 °C) Temperature drift: < 0.005% span/°C
Humidity limits	5 to 95% relative humidity, non-condensing at 140 °F (60 °C)
Electrical	Wire gauge: 0.2 mm ² (24 AWG) minimum, 2.5 mm ² (14 AWG) maximum
Isolation voltage	Power to field side: > 1500 VAC Power to host side: > 500 VAC Field to host side: > 1500 VAC
Power supply (terminals 11 and 12)	18–42 VDC Maximum supply current: 170 mA Maximum power: 3 W
Field side (terminals 1 and 2)	One passive 12–20 mA input <ul style="list-style-type: none"> • Over/under range: 11–21 mA • HART pass-through • Loop supply: > 25 V • HART-compliant impedance: > 250 Ω • I.S. compliance: ATEX, CSA, IECEx
Host side (terminals 23 and 24)	One active or passive 4–20 mA output <ul style="list-style-type: none"> • Over/under range: 2–22 mA • Maximum load limit (active output): < 1 kΩ • Maximum loop voltage (passive input): < 36 V • Response time: < 7 millisecc • Trimmable endpoints (0% and 100%) • Linearity: < 0.05% span Conforms to NAMUR NE43 (February 2003) (depending on transmitter configuration)
EMI effects	Conforms to NAMUR NE21 Version: 08.22.2007

Table B-2 Hazardous area classifications

CSA C-US		Class I, Div. 1, Groups C and D ⁽¹⁾ Class I, Div. 2, Groups A, B, C, and D Class II, Div. 2, Groups F and G
ATEX		II (2) G [Ex ib] IIB/IIC II (2) D [Ex ibD]
IECEx		[Ex ib] IIB/IIC

(1) When installed in a suitable enclosure.

B.4 Mounting and removing the Micro Motion adapter-barrier

The Micro Motion adapter-barrier is designed to be mounted on a DIN rail. The adapter-barrier snaps into place on the DIN rail.

To remove the adapter-barrier from the rail, pull the spring clamp away from the barrier, using the spring clamp release loop. See Figure B-3.

Figure B-3 Mounting and removing the Micro Motion adapter-barrier

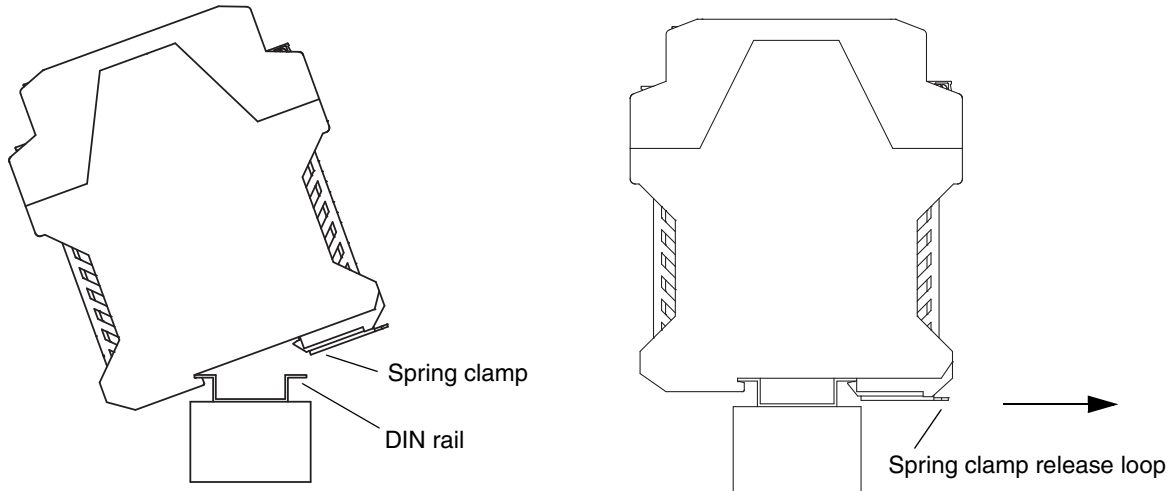

B.5 Unlocking and locking the Micro Motion adapter-barrier

If the adapter-barrier is locked, you will not be able to configure or calibrate the device.

To unlock the adapter-barrier, press **Up Arrow** for three seconds. LED2 will be lit when the device is unlocked.

There are two ways to lock the adapter-barrier:

- Automatic – Return the rotary switch (see Figure B-1) to position 7.  The adapter-barrier will lock itself automatically after two minutes, and LED2 will be turned off.
- “Fast Lock” – Return the rotary switch to position 7 and press **Down Arrow**. The adapter-barrier is locked immediately, and LED2 is turned off.

If the rotary switch is not in position 7, the adapter-barrier cannot be locked.

B.6 Configuring active or passive loop power

By default, the adapter-barrier is “active,” i.e., it powers the host-side loop. To configure the loop power setting of the adapter-barrier (if required):

1. Unlock the adapter-barrier if required (see Section B.5).

2. Set the rotary switch to position 5. 

3. Press **Up Arrow** or **Down Arrow** as desired, and hold for three seconds.

- **Up Arrow** selects active power. After three seconds, LED2 is turned on.
- **Down Arrow** selects passive power. After three seconds, LED2 is turned off.



4. Lock the adapter-barrier (see Section B.5).

B.7 Calibrating the mA output of the Micro Motion adapter-barrier

Calibrating the mA output of the adapter-barrier is used to ensure that the mA signal being sent by the device is being received accurately by the host. You can calibrate the mA output at the 0% and 100% endpoints.

Note: Micro Motion recommends that you perform this calibration procedure as part of a set of testing and commissioning procedures. See the document entitled Micro Motion Model 2200S Transmitters: Configuration and Use Manual.

To calibrate the mA output of the adapter-barrier:

1. Unlock the device if required (see Section B.5).
2. To calibrate the 0% signal:
 - a. At the adapter-barrier, set the rotary switch to position 1. 
 - b. At the Model 2200S transmitter, fix the mA output to 12 mA.
 - c. At the host, check the mA reading from the adapter-barrier. The mA signal should read 4 mA, or the host should be receiving the configured LRV.
 - d. At the adapter-barrier, adjust the mA output from the adapter-barrier so that the mA reading at the host is within tolerance.
 - To increase, press **Up Arrow**.
 - To decrease, press **Down Arrow**.
3. To calibrate the 100% signal:
 - a. At the adapter-barrier, set the rotary switch to position 2. 
 - b. At the Model 2200S transmitter, fix the mA output to 20 mA.
 - c. At the host, check the mA reading from the adapter-barrier. The mA signal should read 20 mA or the host should be receiving the configured URV.
 - d. At the adapter-barrier, adjust the mA output from the adapter-barrier so that the mA reading at the host is within tolerance.
 - To increase, press **Up Arrow**.
 - To decrease, press **Down Arrow**.
4. Lock the adapter-barrier (see Section B.5).
5. At the Model 2200S transmitter, unfix the mA output.

B.8 Resetting the Micro Motion adapter-barrier to factory calibration values

To reset the adapter-barrier to factory calibration values:

1. Unlock the adapter-barrier if required (see Section B.5).

2. Set the rotary switch to position 0. 

3. Press **Up Arrow** and **Down Arrow** simultaneously for ten seconds. When the reset is complete, LED1 and LED2 will flash.

4. Lock the adapter-barrier (see Section B.5).

Appendix A

Dimensions and Specifications

Note: Information in this appendix applies to the Model 2200S transmitter installed on an ELITE® sensor. For additional information on the sensor, see the product data sheet. For information on the Micro Motion adapter-barrier, see Appendix B.

A.1 Dimensions

Figure A-1 shows the dimensions of the Model 2200S transmitter.

Figure A-1 Transmitter dimensions

Dimensions in inches
(mm)

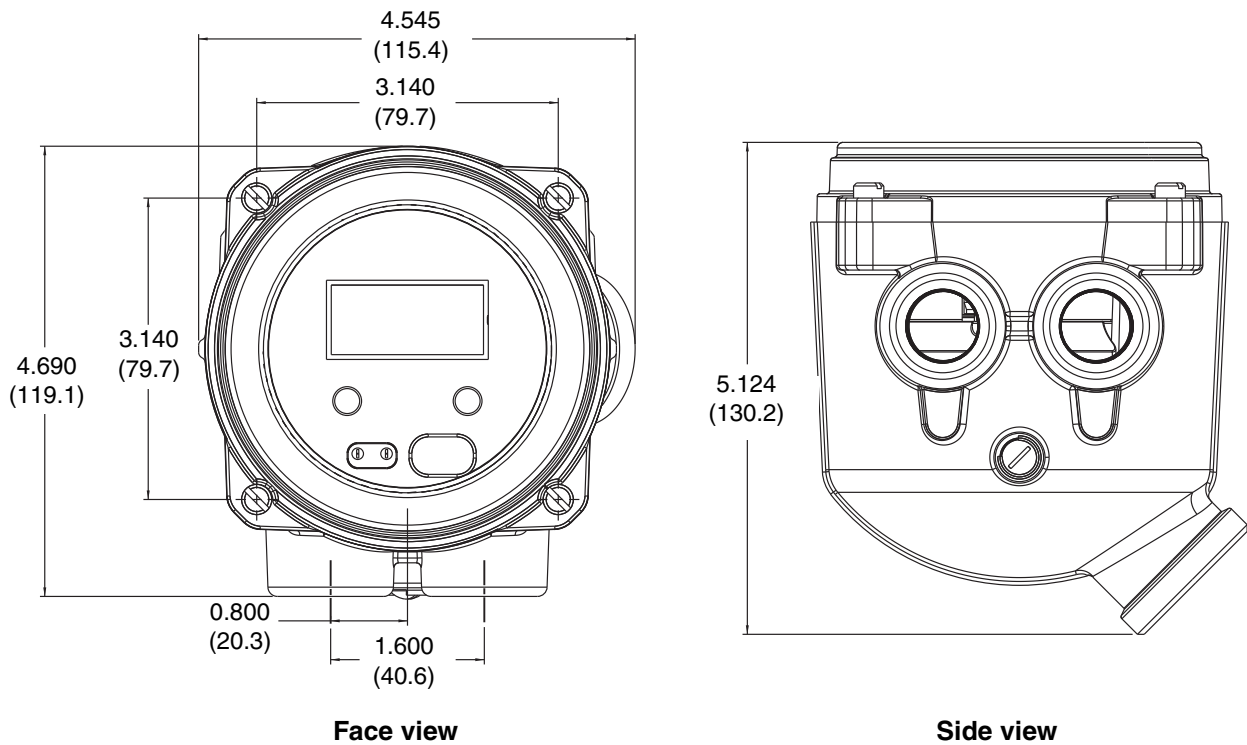

Dimensions and Specifications

A.2 Physical specifications

Housing	NEMA 4X (IP67) polyurethane-painted cast aluminum or 316L stainless steel Available with 1/2" NPT or M20 conduit connections
Mounting	Integral-mount or extended-mount The transmitter can be rotated on the mounting in 45° increments, for eight different orientations
Weight	See product data sheet

A.3 Power supply

DC	17–36 VDC Loop resistance up to 600 Ω 0.8 W maximum
-----------	---

A.4 Electrical connections

Input and output connections	One pair of wiring terminals for transmitter input/output, digital communications, and power. Screw terminals accept solid or stranded conductors, 26 to 14 AWG (0.14 to 2.5 mm ²).
Digital communications administrative connection	Two clips for temporary connection to HART/Bell 202 terminals. Loop resistance is required on main terminals. No resistor is allowed on temporary connections.

A.5 User interface

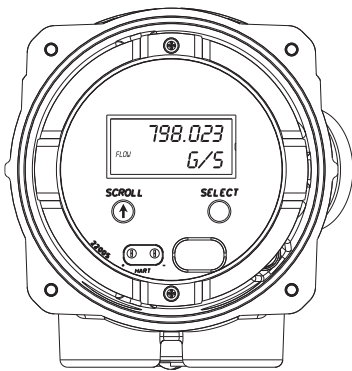

Standard user interface with LCD panel

- Suitable for hazardous area installation.
 - User interface module can rotate 360° on the transmitter in 90° increments.
 - Two clips for HART/Bell 202 connections (requires removing transmitter housing cover).
 - Two membrane pushbuttons for local operation (requires removing transmitter housing cover).
 - Depending on purchase option, transmitter housing cover has glass or plastic lens.
 - User interface module includes LCD panel. LCD line 1 displays process variable; line 2 displays engineering unit of measure, with optional alarm indication.
 - LCD panel can be configured to scroll through display list at user-specified scroll rate. Display list includes user-selected process variables and, optionally, all active alarms.
 - Display update rate is user-configurable: 100 to 10,000 milliseconds.
-

Dimensions and Specifications

A.6 Input/output signals

Channel A	One passive 12–20 mA output <ul style="list-style-type: none">• Isolated to ± 50 VDC from earth ground• Maximum load limit: 600 Ω• External power: 17 to 36 VDC• Can report mass flow, volume flow, gas standard volume flow, density, temperature, or drive gain• Output is linear with process from 11.9 to 20.25 mA• Intrinsically safe (purchase option)
------------------	--

A.7 Digital communications

HART/Bell 202	HART signal is superimposed on the milliamp output, and is available for host system interface: <ul style="list-style-type: none">• Frequency: 1.2 and 2.2 kHz• Amplitude: to 1.0 mA• 1200 baud, one stop bit, odd parity• Address: 0 (default), configurable• Requires 250 to 600 Ω resistance
----------------------	---

A.8 Host interface

HART DD file	Supports full device configuration and functionality
ProLink® II v2.8	Supports full device configuration and functionality Requires HART/Bell 202 connection (RS-485 connections not supported)

A.9 Environmental limits



Ambient temperature limits	Operating and storage: -40 to $+140$ °F (-40 to $+60$ °C) Below -4 °F (-20 °C), LCD responsiveness decreases and LCD may become difficult to read. Above 131 °F (55 °C), some darkening of the LCD panel may occur.
Humidity limits	5 to 95% relative humidity, non-condensing at 140 °F (60 °C)
Vibration limits	Meets IEC68.2.6, endurance sweep, 5 to 2000 Hz, 50 sweep cycles at 1.0 g

A.10 Environmental effects

EMI effects	Complies with EMC directive 2004/108/EC per EN 61326 Industrial Conforms to NAMUR NE21 Version: 08.22.2007
Ambient temperature effect	On mA output: $\pm 0.005\%$ of span per °C

Dimensions and Specifications

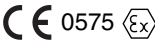
A.11 Hazardous area classifications

CSA C-US		Ambient temperature –40 to +140 °F (–40 to +60 °C) Class I, Div. 1, Groups C and D Class I, Div. 2, Groups A, B, C, and D Class II Div. 1, Groups E, F, and G
ATEX	 	II 2G Ex ib IIB/IIC T4 II 2D Ex ibD 21 T70 °C II 3G Ex nA II T4 II 3D Ex tD A22 IP66/67 T70 °C
IECEX		Ex ib IIB/IIC T4 Ex nA II T4

Appendix C

Return Policy

C.1 General guidelines

Micro Motion procedures must be followed when returning equipment. These procedures ensure legal compliance with government transportation agencies and help provide a safe working environment for Micro Motion employees. Failure to follow Micro Motion procedures will result in your equipment being refused delivery.

Information on return procedures and forms is available on our web support system at www.micromotion.com, or by phoning the Micro Motion Customer Service department.

C.2 New and unused equipment

Only equipment that has not been removed from the original shipping package will be considered new and unused. New and unused equipment requires a completed Return Materials Authorization form.

C.3 Used equipment

All equipment that is not classified as new and unused is considered used. This equipment must be completely decontaminated and cleaned before being returned.

Used equipment must be accompanied by a completed Return Materials Authorization form and a Decontamination Statement for all process fluids that have been in contact with the equipment. If a Decontamination Statement cannot be completed (e.g., for food-grade process fluids), you must include a statement certifying decontamination and documenting all foreign substances that have come in contact with the equipment.

Index

A

Adapter-barrier
 See Micro Motion adapter-barrier

B

Barrier 8
 active vs. passive 8, 18, 30
 and mA output scale 2
 installation
 Micro Motion adapter-barrier 15
 third-party barrier 15
 installation architecture
 Micro Motion adapter-barrier 3
 third-party barrier 3
 requirements 8
 See also Micro Motion adapter-barrier
 third-party barriers verified by Micro Motion 8

C

Calibration
 Micro Motion adapter-barrier 31
 resetting to factory calibration values 32
Customer service 5

D

Dimensions
 Micro Motion adapter-barrier 28
 transmitter 23
Documentation 5

E

Extender 2
 installation 11

F

Flowmeter
 components 2
 documentation 5

G

Grounding requirements 15

I

I.S. barrier
 See Barrier
Installation
 architectures 2
 barrier
 Micro Motion adapter-barrier 15, 30
 third-party barrier 15
 extender 11
 grounding 15
 locating the components 9
 overview 4
 rotating transmitter on sensor 13
 rotating user interface module on transmitter 14
 tips 9
 wiring
 Micro Motion adapter-barrier 18
 no barrier 17
 third-party barrier 18

M

mA output
 calibration 31
 from Micro Motion adapter-barrier 2
 from third-party barrier 2
 from transmitter 2
mA output trim
 See Micro Motion adapter-barrier, calibrating the
 mA output
mA output wiring
 See Wiring
Micro Motion adapter-barrier
 active vs. passive 8, 30
 and mA output scale 2, 27
 calibrating the mA output 31
 dimensions 28
 in model number 1
 installation 15, 30
 mounting and removing 30
 overview 27
 resetting to factory calibration values 32
 specifications 29
 unlocking and locking 30
Micro Motion customer service 5
Model number 1

Index

P

Power

- barrier requirements 8
- transmitter requirements 7

Power wiring

See Wiring

R

Requirements

- barrier 8
- power to barrier 8
- power to transmitter 7

Return policy 33

S

Safety barrier

See Barrier

Safety messages 1

Scale

See mA output scale

Sensor 2

Specifications

- Micro Motion adapter-barrier 29
- transmitter 23

T

Transmitter 2

- dimensions 23
- documentation 5
- installation overview 4
- model number 1
- mounting options 2
- orientation 13
- power requirements 7
- rotating on sensor 13
- rotating user interface module 14
- specifications 23
- type 1

U

User interface module

- rotating 14

W

Wiring 17

- active vs. passive barrier 18
- Micro Motion adapter-barrier 18
- no barrier 17
- third-party barrier 18

©2009, Micro Motion, Inc. All rights reserved. P/N MMI-20012740, Rev. BA



For the latest Micro Motion product specifications, view the
PRODUCTS section of our web site at www.micromotion.com

Micro Motion Inc. USA

Worldwide Headquarters

7070 Winchester Circle
Boulder, Colorado 80301

T +1 303-527-5200

+1 800-522-6277

F +1 303-530-8459

Micro Motion Europe

Emerson Process Management

Neonstraat 1

6718 WX Ede

The Netherlands

T +31 (0) 318 495 555

F +31 (0) 318 495 556

Micro Motion Asia

Emerson Process Management

1 Pandan Crescent

Singapore 128461

Republic of Singapore

T +65 6777-8211

F +65 6770-8003

Micro Motion United Kingdom

Emerson Process Management Limited

Horsfield Way

Bredbury Industrial Estate

Stockport SK6 2SU U.K.

T +44 0870 240 1978

F +44 0800 966 181

Micro Motion Japan

Emerson Process Management

1-2-5, Higashi Shinagawa

Shinagawa-ku

Tokyo 140-0002 Japan

T +81 3 5769-6803

F +81 3 5769-6844

